

# NE-12523

## 1200 Watt\* Commercial Microwave Oven

### Technical Specifications

- Power source:** 60Hz, Single phase
- Receptacle required:** NEMA 5-20R 
- Frequency:** 2,450MHz
- Required power:** 120: (17.7A)
- Output\*:** 1200 Watts
- Outer dimensions:** 16 5/8" w x 20" d x 13 3/16" h
- Cavity dimensions:** 13" w x 12" d x 6 7/8" h
- Net weight:** 68 lbs.
- Shipping weight:** 73 lbs.
- Shipping box size:** 19 5/16" w x 24 1/8" d x 16 7/8" h, 4.7 ft<sup>3</sup>
- Warranty:** 3 Year Parts, Labor and Travel/Shipping



### To specify a Panasonic Commercial Microwave Oven:

The NE-12523 Commercial Microwave Oven meets or exceeds all safety performance and sanitation standards set for commercial food service microwave ovens by: UL, HHS, FCC and NSF.

Plus, oven shall have output power 1200 Watts\*, Independently controlled top and bottom energy feed, Grab & Go door handle, Automatic Voltage Selector, patented Safety Door Seal System, 90 programmable memory pads, 5-stage cooking, 15 power levels, LCD digital display w/countdown, energy efficient LED cavity lighting, programmable lock, self-diagnostics, oven cycle counter, stackable, video training and Chef/Test Kitchen technical support.

*\* I.E.C. 705-88 Test Procedure. Specifications subject to change without notice.*

### Receptacle Required

2 Pole  
3 Wire

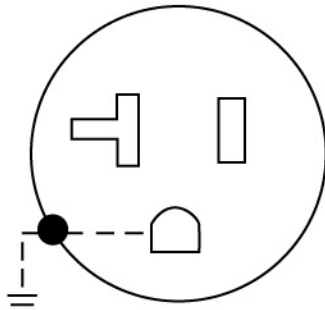

**NEMA Reference:**  
Receptacle: 5-20R  
Plug: 5-20P

**ADA Compliance**  
§4.28.2 ((CFR) –  
28CFR Part 36)  
“For Alarms”.

§4.27 “For controls  
and operating  
mechanisms”.

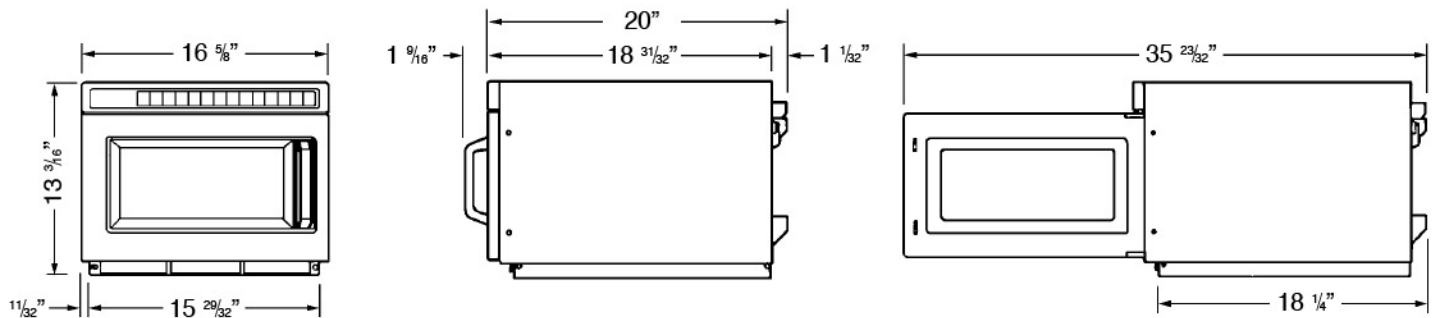

**Panasonic Appliance & Commercial Group**  
Division of PNA  
Executive Offices:  
One Panasonic Way, Panazip 4A-1, Secaucus, NJ 07094  
Toll Free: 1-888-350-9590  
[www.panasonic.com/cmo](http://www.panasonic.com/cmo)